

Go to www.tsicustomerservice.com for product warranty registration

ASSEMBLY INSTRUCTIONS

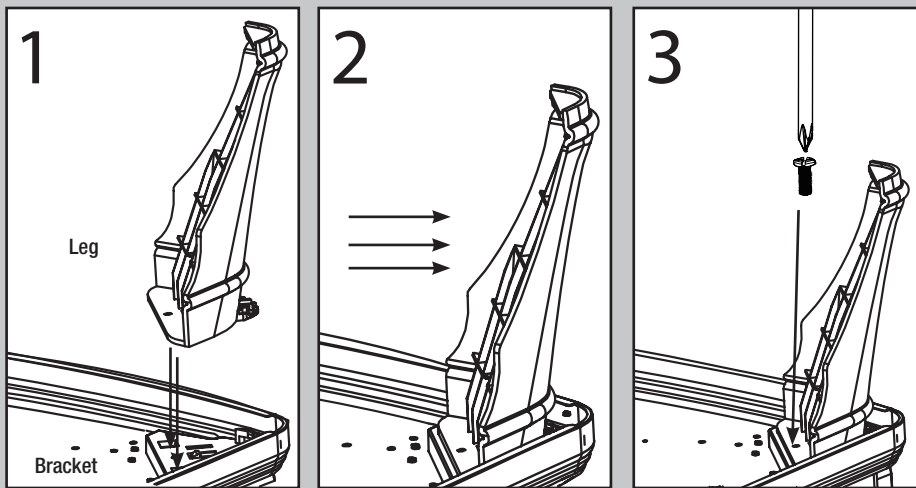

MOUNTING THE LEGS

1. Align the 2 mounting tabs into the bracket (Fig 1)
2. Slide the legs outward to lock in place. The legs will snap into place when correctly installed. (Fig 2)
3. Fasten the legs to the base using the included screws, 1 per leg. If the screw hole does not line up check that the legs are properly snapped into place. (Fig 3)

REPLACING THE LIGHT BULB

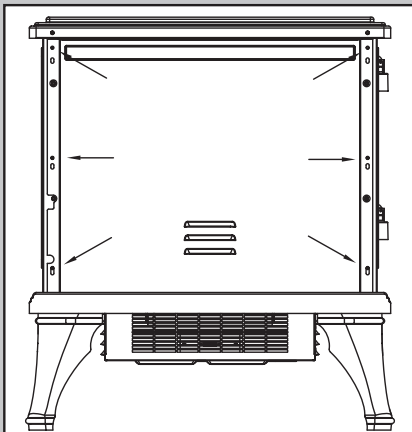

1. Loosen Phillips head screws and remove back panel.

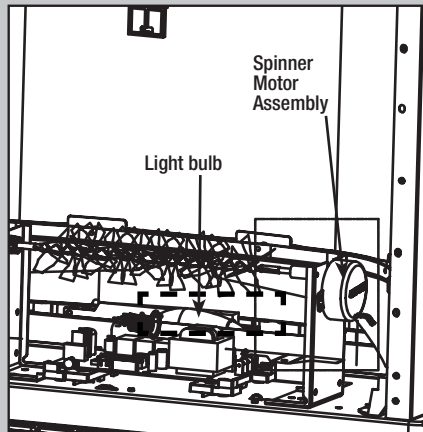

2. Remove back panel to access light bulb

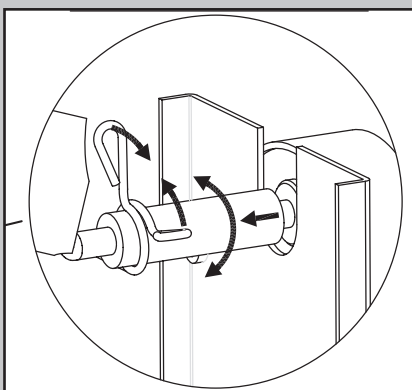

3. Pinch this spring clip to loosen. Gently turn and pull the rubber grommet of the motor shaft.

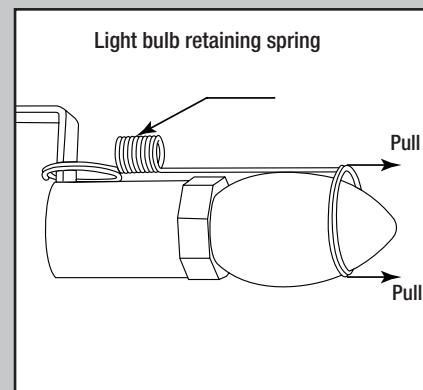

4. Pull away the bulb retaining spring, unscrew the old bulb, and replace with a new 40w candelabra bulb.

OPERATING INSTRUCTIONS

- POWER

- Use the power button to turn on or off the stove from the remote or control panel.

- FLAME

- Use the + and - buttons to adjust the flame brightness.

-HEATER

- Press the HEATER button to cycle through 1000W, 1500W and OFF.

- The heater will beep once when set to 1000W, twice for 1500W, and three times for OFF.

PRODUCT SPECIFICATIONS

VOLTAGE	120 VAC, 60 Hz
AMPS	12.5 Amps
WATTS	1500 Watts

For Customer Service:

www.twinstarhome.com

888-674-7517

8:30 a.m.-5:30 p.m., EST, Monday-Friday

Note: When first running the heater there can be an odor. This is normal, the heater has a surface coating on the internal parts, for the first several hours of operation the coating reacts with the internal parts to permanently protect them. The odor is safe; if you are sensitive to the odor it is recommended to run the heater in a well-ventilated area until the odor dissipates.

Warning: This is an unvented, electric appliance. DO NOT attempt to burn wood or manufactured firelogs in or on this appliance or grate.

Distributed by

Twin-Star International, Inc. Under license. duraflame™ and the duraflame flame logo are trademarks of Duraflame, Inc.

Twin-Star International, Inc.

Delray Beach, FL 33445

Made in China • Printed in China

Made in China

Printed in China

© 2014, Twin-Star International, Inc.

IMPORTANT INSTRUCTIONS

When using electrical appliances, basic precautions should always be followed to reduce the risk of fire, electrical shock, and injury to persons including the following:

1. Read all instructions before using this appliance.
2. This appliance is hot when in use. To avoid burns, do not let bare skin touch hot surfaces. If provided, use handles when moving this appliance. Keep combustible materials, such as furniture, pillows, bedding, papers, clothes and curtains at least 3 feet (0.9 m) from the front of this appliance. **WARNING:** In order to avoid overheating, do not cover the heater.
3. **CAUTION:** Never leave the heater operating unattended. Extreme caution is necessary if unsupervised children or invalids are nearby.
4. The appliance is not to be used by children or persons with reduced physical, sensory or mental capabilities, or lack of experience and knowledge, unless they have been given supervision or instruction.
5. Always unplug this appliance when not in use.
6. Do not operate any heater with a damaged cord or plug or after the appliance malfunctions, or if it has been dropped or damaged in any manner.
7. If the supply cord is damaged, it must be replaced by the manufacturer, its service agent or similarly qualified persons in order to avoid a hazard.
8. Do not use outdoors.
9. This heater is not intended for use in bathrooms, laundry areas and similar indoor locations. Never locate this appliance where it may fall into a bathtub or other water container.
10. Do not run cord under carpeting. Do not cover cord with throw rugs, runners or the like. Arrange cord away from traffic areas and where it will not be tripped over.
11. To disconnect this appliance, turn controls to the off position, then remove plug from outlet.
12. Do not insert or allow foreign objects to enter any ventilation or exhaust opening as this may cause an electric shock or fire, or damage the appliance.
13. To prevent a possible fire, do not block air intakes or exhaust in any manner. Do not use on soft surfaces, like a bed, where opening may become blocked.
14. This appliance has hot and arcing or sparking parts inside. Do not use it in areas where gasoline, paint or flammable liquids are used or stored. This stove should not be used as a drying rack for clothing. Christmas stockings or decorations should not be hung in the area of it.
15. Use this appliance only as described in the manual. Any other use not recommended by the manufacturer may cause fire, electric shock or injury to persons.
16. This appliance, when installed, must be electrically grounded in accordance with local codes or, in the absence of local codes, with the current CSA C22.2 Canadian Electrical Code or for U.S.A. installations, follow local codes and the National Electrical Code, ANSI/NFPA NO.70.
17. Connect to properly grounded outlets only, See Fig.1. This heater is for use on 120 volts. Do not use a 2 prong adapters. Always plug heaters directly into a wall outlet/receptacle. Never use with an extension cord or relocatable power tap (outlet/power strip).

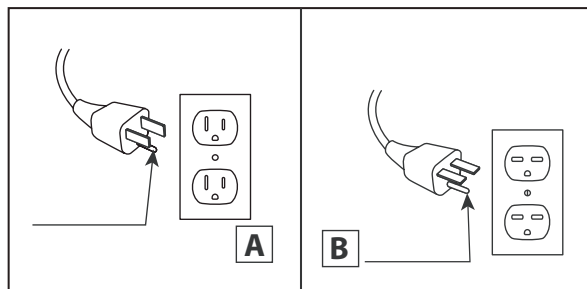

Fig.1



Warning: Changes or modifications to this unit not expressly approved by the party responsible for compliance could void user's authority to operate the equipment.

NOTE: This equipment has been tested and found to comply with the limits for Class B digital device, pursuant to part 15 of the FCC Rules. These limits are designed to provide reasonable protection against harmful interference in a residential installation. This equipment generates, uses, and can radiate radio frequency energy and, if not installed and used in accordance with the instructions, may cause harmful interference to radio communications.

However, there is no guarantee that interference will not occur in a particular installation. If this equipment does cause harmful interference to radio or television reception, which can be determined by turning the equipment off and on, the user is encouraged to try to correct the interference by one or more of the following measures.

- Reorient or relocate the receiving antenna.
- Increase the separation between the equipment and the receiver.
- Connect the equipment into an outlet on a circuit different from that to which the receiver is connected.
- Consult the dealer or an experienced radio/TV technician for help.

This device complies with Part 15 of the FCC Rules.

Operation is subject to the following two conditions:

- (1) This device may not cause harmful interference, and
- (2) this device must accept any interference received, including interference that may cause undesired operation. Modifications not approved by the party responsible for compliance could void user's authority to operate the equipment.

1-YEAR LIMITED WARRANTY

The manufacturer warrants that your new Electric Stove is free from manufacturing and material defects for a period of one year from date of purchase, subject to the following conditions and limitations.

1. Install and operate this Electric Stove in accordance with the installation and operating instructions furnished with the product at all times. Any unauthorized repair, alteration, willful abuse, accident, or misuse of the product shall nullify this warranty.
2. This warranty is non-transferable, and is made to the original owner, provided that the purchase was made through an authorized supplier of the product.
3. The warranty is limited to the repair or replacement of part(s) found to be defective in material or workmanship, provided that such part(s) have been subjected to normal conditions of use and service, after said defect is confirmed by the manufacturer's inspection.
4. The manufacturer may, at its discretion, fully discharge all obligations with respect to this warranty by refunding the wholesale price of the defective part(s).
5. Any installation, labor, construction, transportation, or other related costs/expenses arising from defective part(s), repair, replacement, or otherwise of same, will not be covered by this warranty, nor shall the manufacturer assume responsibility for same.
6. The owner/user assumes all other risks, if any, including the risk of any direct, indirect or consequential loss or damage arising out of the use, or inability to use the product, except as provided by law.
7. All other warranties – expressed or implied –with respect to the product, its components and accessories, or any obligations/liabilities on the part of the manufacturer are hereby expressly excluded.
8. The manufacturer neither assumes, nor authorizes any third party to assume on its behalf, any other liabilities with respect to the sale of the product.
9. The warranties as outlined within this document do not apply to non accessories used in conjunction with the installation of this product.

This warranty is void if:

- a. The fireplace is subjected to prolonged periods of dampness or condensation.
- b. Any unauthorized alteration, willful abuse, accident, or misuse of the product.
- c. You do not have the original receipt of purchase.

IF WARRANTY SERVICE IS NEEDED

Contact the manufacturer by calling customer service department at 1-888-674-7517, 7 days a week/24 hours a day/365 days per year. Make sure you have your warranty, your sales receipt, location of purchase and the model/serial number of your product.

Battery Replacement

Note: Batteries should be removed if the product is to be left unused for a long time.

1. The battery compartment is located on the back end of the remote control.
2. Press and slide the battery door open and remove the old battery.
3. Insert 2 AAA batteries, checking that the + and - sides of the battery match inside the battery compartment.
4. Replace the battery compartment door.

Note: Do not mix old and new batteries. Do not mix alkaline, standard (carbon zinc), or rechargeable (nicad, nimh, etc) batteries.

DISPOSAL OF USED BATTERIES

Battery may contain hazardous substances which could endanger the environment and human health. Used batteries shall not be treated as municipal waste, but left at the appropriate collection point for recycling.

For more information about collection and recycling of used batteries, please contact your local municipality or waste disposal service.

**SAVE THESE
INSTRUCTIONS**